

ASSEMBLY INSTRUCTIONS FOR BORROUGHS

WB132 series & WB122 series Work Benches

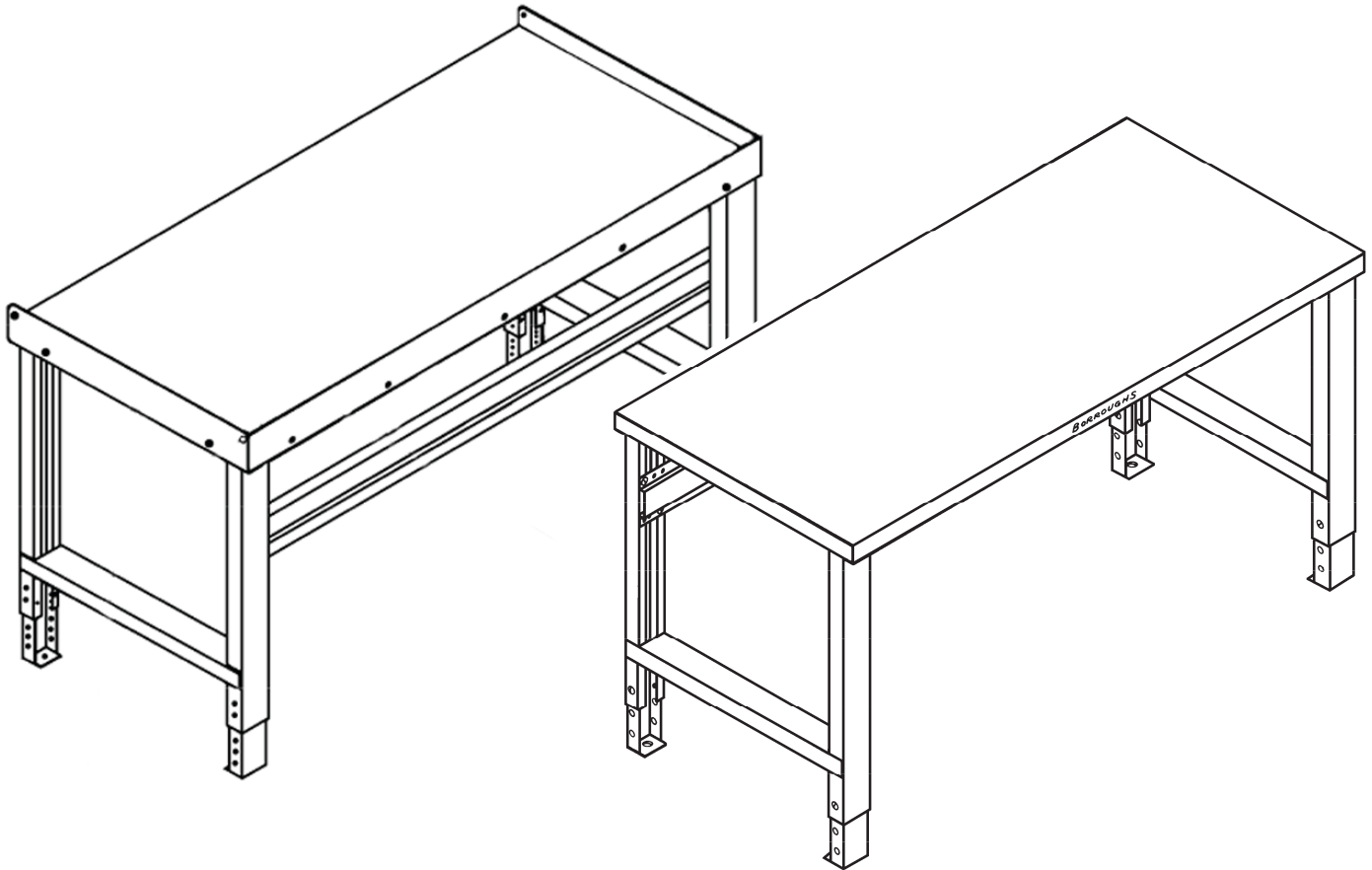

LIMITED LIFETIME WARRANTY

Borroughs Corporation extends to the original purchaser from the date of purchase a lifetime limited warranty against manufacturing defects in material and workmanship. If a Borroughs product fails to perform because of a manufacturing defect, Borroughs will examine it. If found defective, it will be repaired or replaced at our option. This warranty applies only to Borroughs products acquired directly from Borroughs Corporation or from Authorized Borroughs Dealers. This warranty does not apply to any product which has been subject to misuse, negligence, or accident; has been damaged in shipment, storage, or installation; has been misapplied or has been modified or repaired by unauthorized persons or been repaired with non-standard Borroughs replacement parts. This warranty specifically excludes claims for indirect, incidental, or consequential damages arising in any way from a product defect. This warranty is exclusive, and exists in lieu of all other warranties, either expressed or implied. This warranty gives you specific legal rights; you may also have other rights which may vary from state to state. Contact your Borroughs Selling Dealer, to obtain warranty service. You must make a written claim. Provide a copy of your purchase record and a written description of the warranty problem with your claim.

CONTENTS

Basic Work Bench	2	End Guards or Back Guard	3
Leveler Foot Plate	2	End Guards and Back Guard Combined	3
Shelf for Basic Work Bench.....	2	Limited Lifetime Warranty.....	4

IMPORTANT - PRODUCT LIABILITY INFORMATION

Read all instructions before proceeding with installation. Vital product information pertaining to proper set-up and cautions are included. Failure to follow these instructions may result in personal injury and/or property damage.

RETAIN THIS MANUAL FOR FUTURE REFERENCE



Borroughs Corporation
 3002 N. Burdick Street, Kalamazoo, MI 49004
t: 800-748-0227 | f: 269-342-4161 | www.borroughs.com
 ISO 14001:2004 and 9001:2008 Registered
 Printed in the USA | ©2016 Borroughs Corporation | Form # 1-50374-WB132-122



3002 N. Burdick Street, Kalamazoo, MI 49004
t: 800-748-0227 | f: 269-342-4161 | www.borroughs.com
 ISO 14001:2004 and 9001:2008 Registered

1-50374-WB132-122
 April 2016

Basic Work Bench

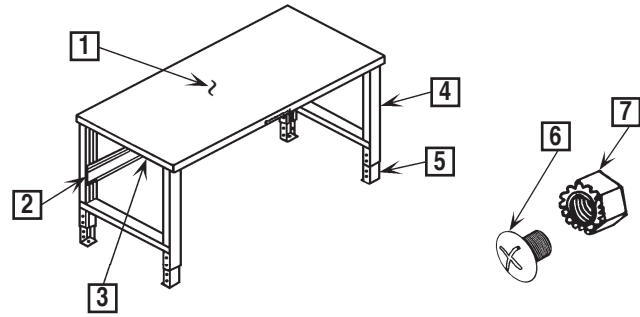

Parts List "A"		
Item	Description	Req'd.
1	Bench Top	1
2	Stringer	1
3	Leg Attachment Channel	2
4	Leg Weldment	2
5	Adjustable Foot	4
6	.312 (5/16) - 18 x .500 (1/2) Phillips T.H.M.S.	40
7	.312 (5/16) - 18 Keps Nut	32
8	.312 (5/16) - 18 Weldnut	8

Tools Required: 1. Phillips Screwdriver
2. 1/2" Open End or Box Type Wrench

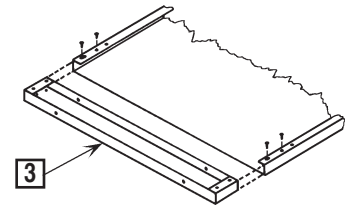

FIGURE 1

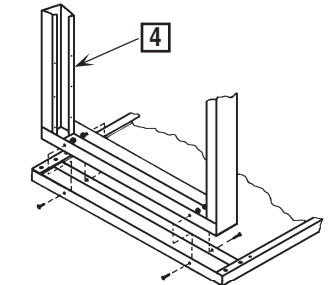

FIGURE 2

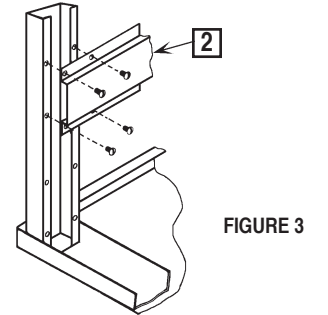

FIGURE 3

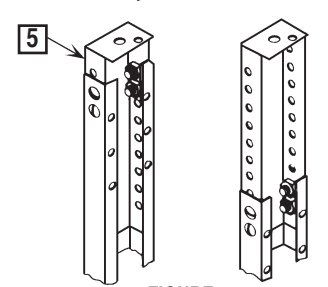

FIGURE 4

- Lay bench top (Item 1) upside down on a flat surface.
- Insert leg attachment channel (Item 3) into bench top with the open area of channel facing upward. Position attachment channel so that the holes in the end flanges are in line with the oval and first hole in the front and back flanges of the bench top. Fasten channel to bench top with (4) screws and nuts (Items 6 & 7) as provided in the **hardware pack 293**. See Figure 1. Repeat procedure at the other end.
- Stand leg weldment (Item 4) in place. (Leg fits inside attachment channel). Position leg so that holes in the sides of the leg weldment are in line with the holes in the sides of the attachment channel. Loosely fasten leg and channel together with (4) screws and nuts (Items 6 & 7) as provided in **hardware pack 293**. See Figure 2. Repeat procedure at the other end.
- The stringer (Item 2) is to be attached so the legs along the back edges of bench. (BORROUGHS is stamped on the front edge of Bench). Position stringer so that the holes in the end of the stringer are in line with the holes in the leg. Fasten stringer to leg with (4) screws and weldnuts (Items 6 & 8) as provided in **hardware pack 664**. See Figure 3. Repeat procedure at the other end. Tighten screws holding leg weldments and attachment channels together.
- Insert adjustable foot (Item 5) into leg so that the holes in the sides of the foot are aligned with the holes in the sides of the leg. At the desired height, fasten foot to leg with (4) screws and nuts (Items 6 & 7) as provided in **hardware pack 293**. See Figure 4. Repeat procedure for the other legs.

This completes assembly of the Basic Work Bench. Put bench in upright position.

Leveler Foot Plate

Parts List "C"		
Item	Description	Req'd.
1	Foot Plate Assembly	2 pair
2	.312 (5/16) Keps Nut	4
3	.312 (5/16) - 18 x .500 (1/2) Phillips T.H.M.S.	4

Tools Required: 1. Phillips Screwdriver
2. 1/2" Open End or Box Type Wrench

- Lay work bench upside down on a flat surface.
- Position the foot plate assembly (Item 1) so that the tee nut and leveling screw align with and fits into the center hole in the bottom flange of the adjustable foot. The hole in the corner of both the foot plate assembly and the adjustable foot should also be in line with each other. Fasten the foot plate assembly to the adjustable foot with (1) screw and nut (Items 2 & 3) as provided in **hardware pack 296**. Repeat procedure to the other legs of the unit.
- Place work bench in upright position. Adjust leveling screws until work bench is at the desired leveled position.

This completes assembly of the Leveler Foot Plate.

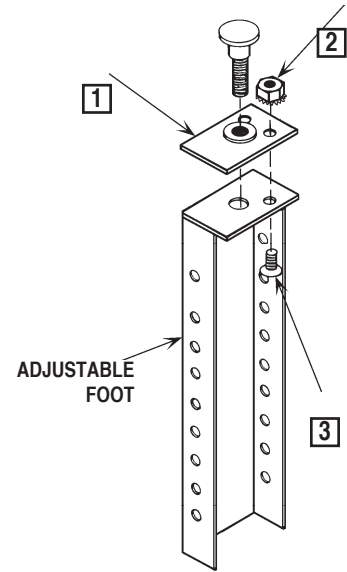

Shelf for Basic Work Bench

Parts List "D"		
Item	Description	Req'd.
1	Bench Shelf	1
2	.312 (5/16) - 18 x .500 (1/2) Phillips T.H.M.S.	4
3	.312 (5/16) - 18 Keps Nut	4

Tools Required: 1. Phillips Screwdriver
2. 1/2" Open End or Box Type Wrench

Place the shelf (Item 1) on the shelf supports between the legs of the work bench with the back edge of the shelf (the edge with the 90° flange is the back) approximately .062 (1/16") from the back legs of the work bench. Position shelf so the two inner holes on each end of the shelf are in line with the two inner holes of each shelf support. Fasten the shelf to the shelf supports with (4) screws and nuts (Items 2 & 3) as provided in **hardware pack 2**, two each end. See Figure 10.

This completes the Shelf assembly for the Basic Work Bench.

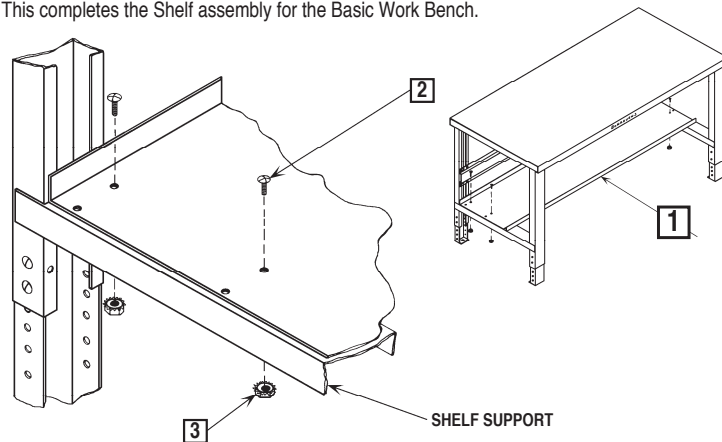

FIGURE 10

End Guards (applies to 132 series)

Parts List "F"		
Item	Description	Req'd.
1	End Guard	1 pair
2	.312 (5/16) - 18 x .500 (1/2) Phillips T.H.M.S.	4
3	.312 (5/16) - 18 Keps Nut	4

Tools Required: 1. Phillips Screwdriver
2. 1/2" Open End or Box Type Wrench

Position end guard (Item 1) so that the two holes align with the holes in the side of the attachment channel. Fasten end guard to channel with (2) screws and nuts (Items 2 & 3) as provided in **hardware pack 2**. Repeat procedure at the other end.

This completes the End Guard assembly.

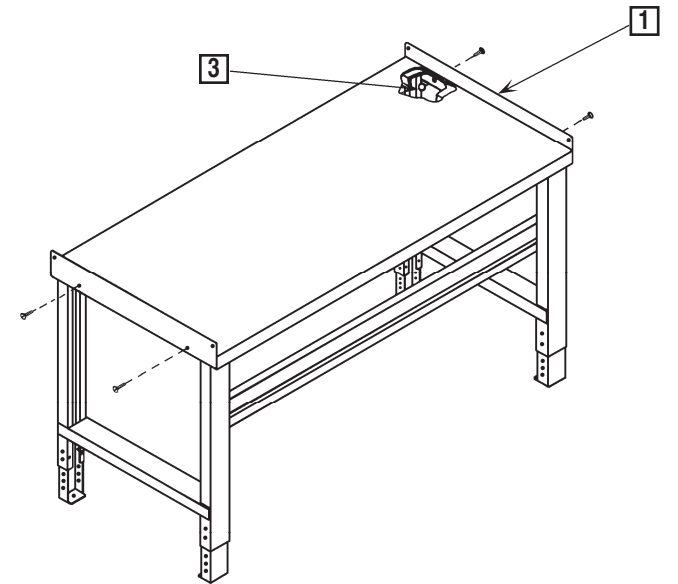

Back Guard (applies to 132 series)

Parts List "G"		
Item	Description	Req'd.
1	Back Guard	1
2	.312 (5/16) - 18 x .500 (1/2) Phillips T.H.M.S.	7
3	.312 (5/16) - 18 Keps Nut	7

Tools Required: 1. Phillips Screwdriver
2. 1/2" Open End or Box Type Wrench

Position back guard (item 1) so that the ovals in the lower edge of the back guard are in line with the holes in the back edge of the bench top. (Flanges on the back guard are to be facing toward the front). Fasten back guard to bench top with (5) screws and nuts (Items 2 & 3) as provided in **hardware pack 293**.

This completes the Back Guard assembly.

NOTE: The extra (2) screws and nuts are used when the end guards and back guard are combined on the work bench.

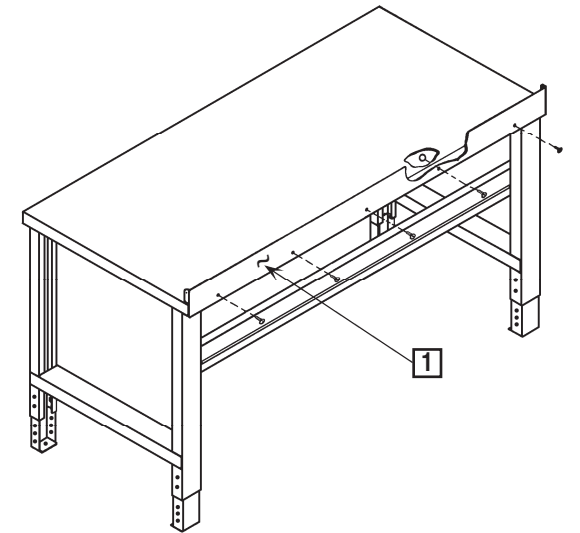

End Guards and Back Guard Combined (applies to 132 series)

Attach end guards and back guard to work bench as stated in the separate assemblies for the end guards and back guard above. Flanges on back guard are to be located inside of the end guards. Fasten end guards to back guard with (1) screw and nut (Items 2 & 3) as provided in **hardware pack 293**, at each corner.

This completes the assembly for the End Guards and Back Guard Combined.

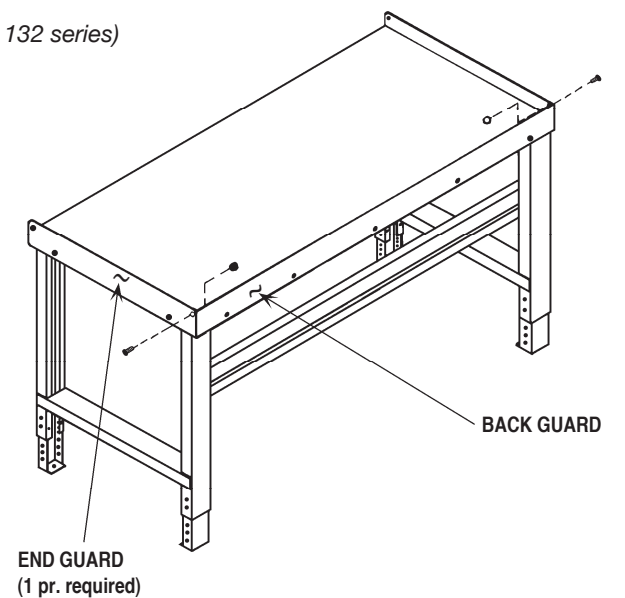

END GUARD
(1 pr. required)

BACK GUARD