

Sloped Top Shop Desk and Cabinet Conversion Kit Assembly Instructions

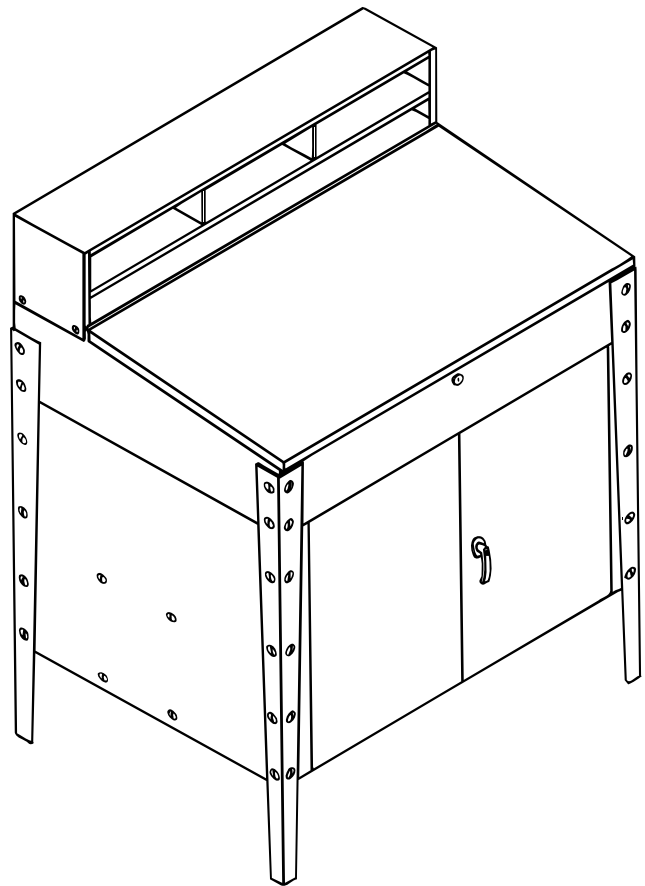
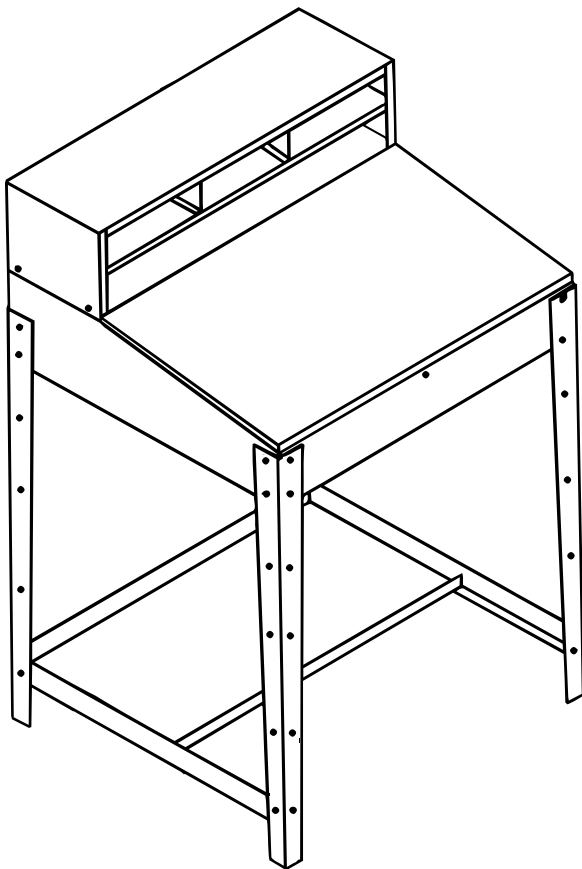

IMPORTANT - PRODUCT LIABILITY INFORMATION

Read all instructions before proceeding with installation. Vital product information pertaining to proper set-up and cautions are included. Failure to follow these instructions may result in personal injury and/or property damage.

RETAIN THIS MANUAL FOR FUTURE REFERENCE

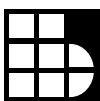

Borroughs
CORPORATION

3002 N. BURDICK ST. ■ KALAMAZOO, MI 49004-3483
800-748-0227 ■ FAX: 269-342-4161 ■ www.borroughs.com

09-50195-00B
JUNE 1998
(logo rev. 2004)

Sloped Top Shop Desk Assembly Instructions (Cabinet Conversion Kit instructions begin on page 4)

1. Remove all items from carton and check parts against the following list:

PARTS LIST "A"

Item	Description	Required
1	Shop Desk Assembly	1
2	Rack Assembly	1
3	Leg Assembly - 39"	4
4	Stringer	2
5	Shelf	1
6	5/16-18 Keps Nut - Zinc Plated	24
7	5/16-18 x 1/2 Phillips T.H.M.S. - Zinc Plated	24
8	No. 10 x 3/8 T.H.S.M.S. - Zinc Plated	4
9	Rubber Bumper	2
10	Lock Assembly	1

- Tools Required:
1. 1/2" Open End Wrench
 2. Phillips Screwdriver

2. Stand the shop desk assembly (Item 1) on its back with top in open position. See Figure 1.

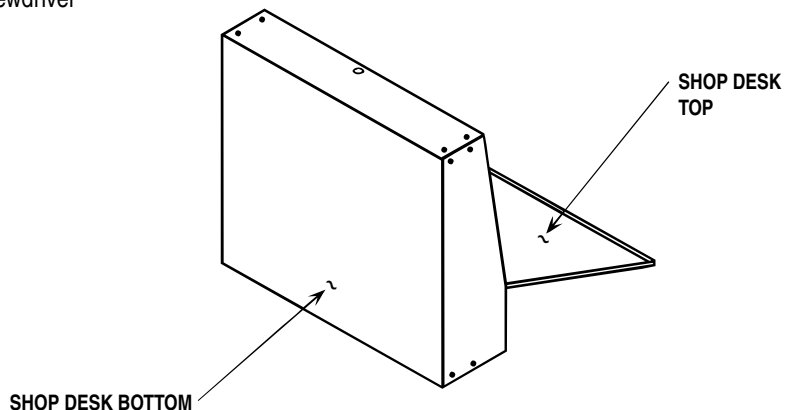

FIGURE 1

3. Using four (4) nuts and screws (Items 6 & 7 respectively) for each leg assembly (Item 3), attach one leg assembly to each corner of the shop desk assembly. See Figure 2. **Finger tighten only** - sixteen (16) nuts and screws.

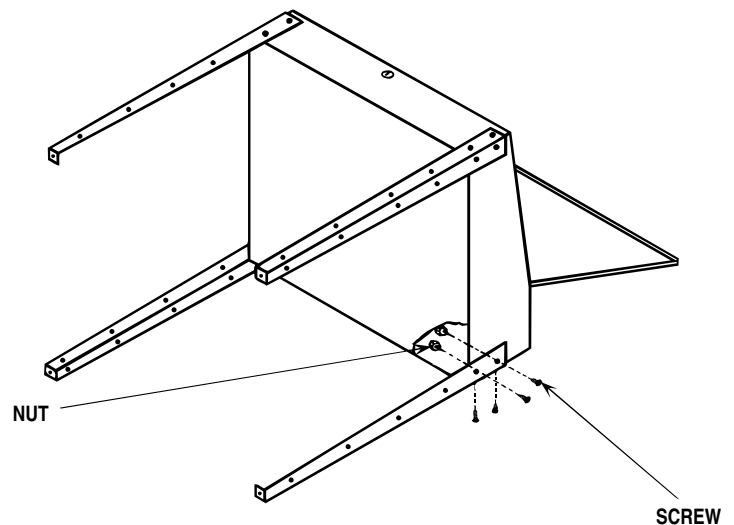

FIGURE 2

4. Making sure hands are clear, CLOSE TOP and stand desk upright. Attach stringers (Item 4) with four (4) nuts and screws (Items 6 & 7) - two (2) each side - in the bottom holes on the inside of the leg assembly. See Figure 3. **Finger tighten only.**

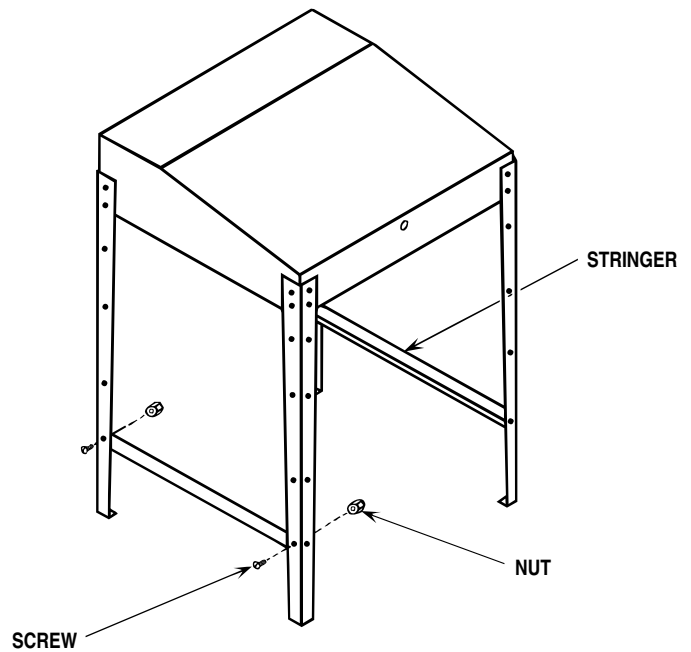

FIGURE 3

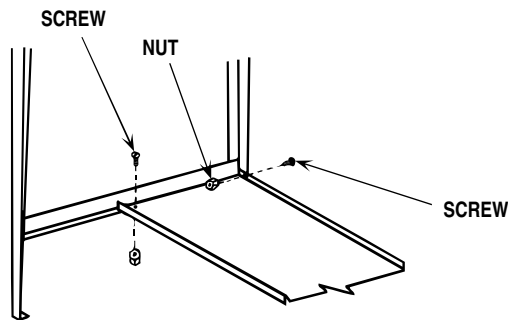

FIGURE 4

5. Attach shelf (Item 5) to the stringers in the front and to the leg assemblies in the rear with four (4) nuts and screws (Items 6 & 7) - two (2) each side as shown. See Figure 4. **Finger tighten only.**

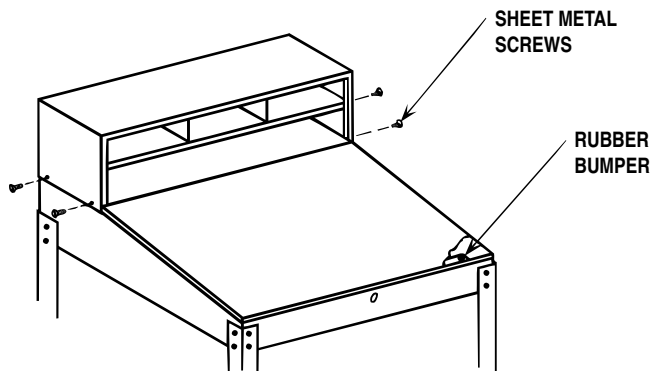

FIGURE 5

6. Position rack assembly (Item 2) on top of desk, align holes and fasten together with four (4) sheet metal screws (Item 8) as shown. See Figure 5. Tighten with a Phillips screwdriver.
7. Insert rubber bumpers (Item 9) into slots on the side edges of the desk. See Figure 5.

CAUTION

**VERY IMPORTANT - Move desk into workstation position and level.
TIGHTEN ALL SCREWS and NUTS with a 1/2" wrench and a Phillips screwdriver.**

8. Insert lock (Item 10) into lock hole in desk front. Open top and slide snap fastener over lock, securing it in place. Close top. Insert key and test locking capability.

CAUTION

**MAKE SURE ALL HANDS AND FINGERS ARE CLEAR BEFORE CLOSING TOP.
DO NOT LEAVE OPEN AND UNATTENDED.
DO NOT WEDGE OPEN.**

Cabinet Conversion Kit Assembly Instructions

1. Remove all items from carton and check parts against the following list:

PARTS LIST "B"

Item	Description	Required
1	Handle Reinforcement	1
2	Door Handle with Lock	1
3	Cam	1
4	#8-32 x 5/16 SEMS Screw	2
5	5/16-18 x 1/2 Phillips T.H.M.S. - Zinc Plated	44
6	5/16 - 18 Keps Nut - Zinc Plated	44
7	Door Frame	1
8	Door - Right Hand	1
9	Door - Left Hand	1
10	Throwbolt	2
11	Back Panel	1
12	Side Panel	2
13	Shelf - Upper	1
14	Shelf - Bottom	1
15	Push Clip	1

- Tools Required:
1. 1/2" Open End Wrench
 2. Phillips Screwdriver

2. Remove rack, shelf and stringers from desk.
See Figure 6. **NOTE:** Lay desk upside down on a clean, smooth surface. Protect top surface with wooden blocks under front edge of desk to rest unit in level position.

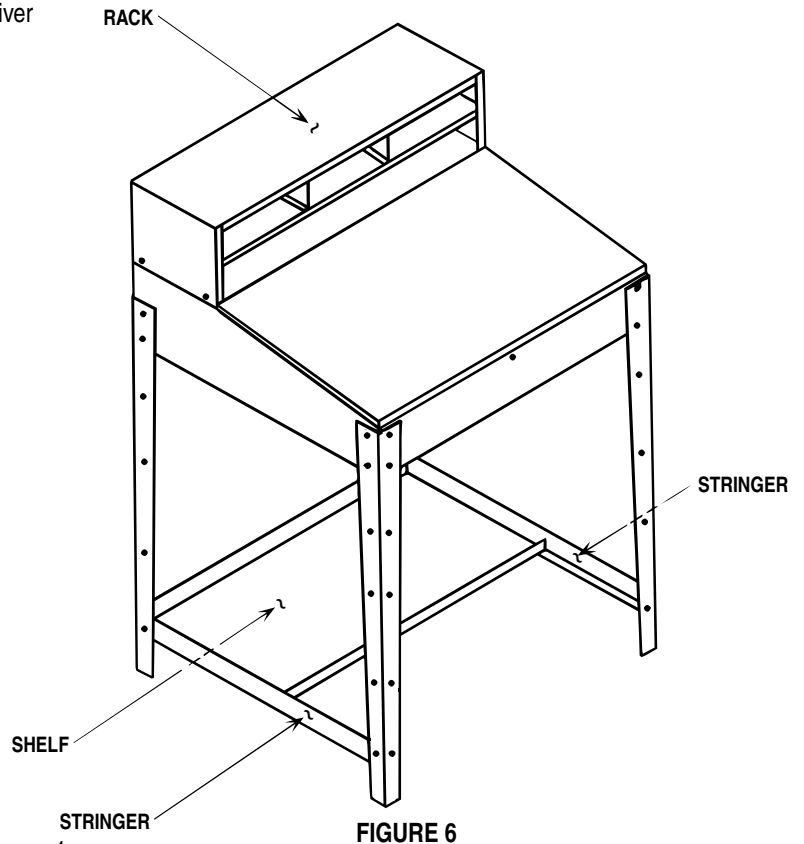

3. Remove doors from door frame (Item 7). See Figure 7.

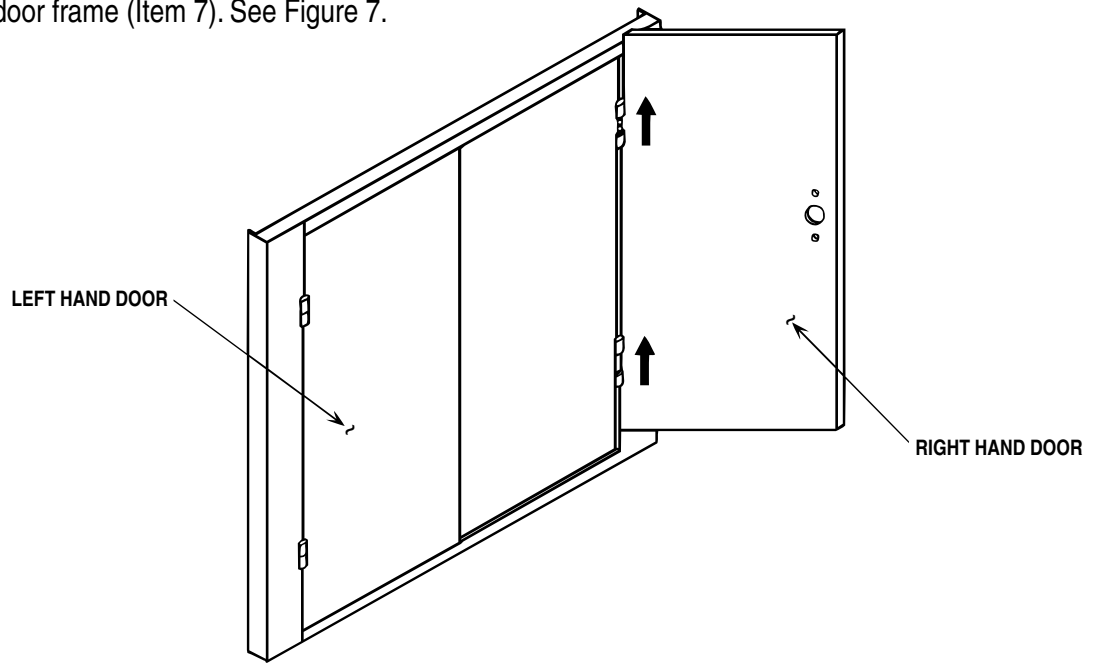

FIGURE 7

4. See Figure 8 and . . .

a. Place side panels (Item 12) and back panel (Item 11) into position.

b. Insert door frame (Item 7) into unit.
NOTE: Tilt frame between side panels and pull to front of unit. Top of frame must be down.

c. Fasten side panels, back panel and door frame to legs of desk, with sixteen (16) screws and nuts (Items 5 & 6) at two levels closest to the top of desk.

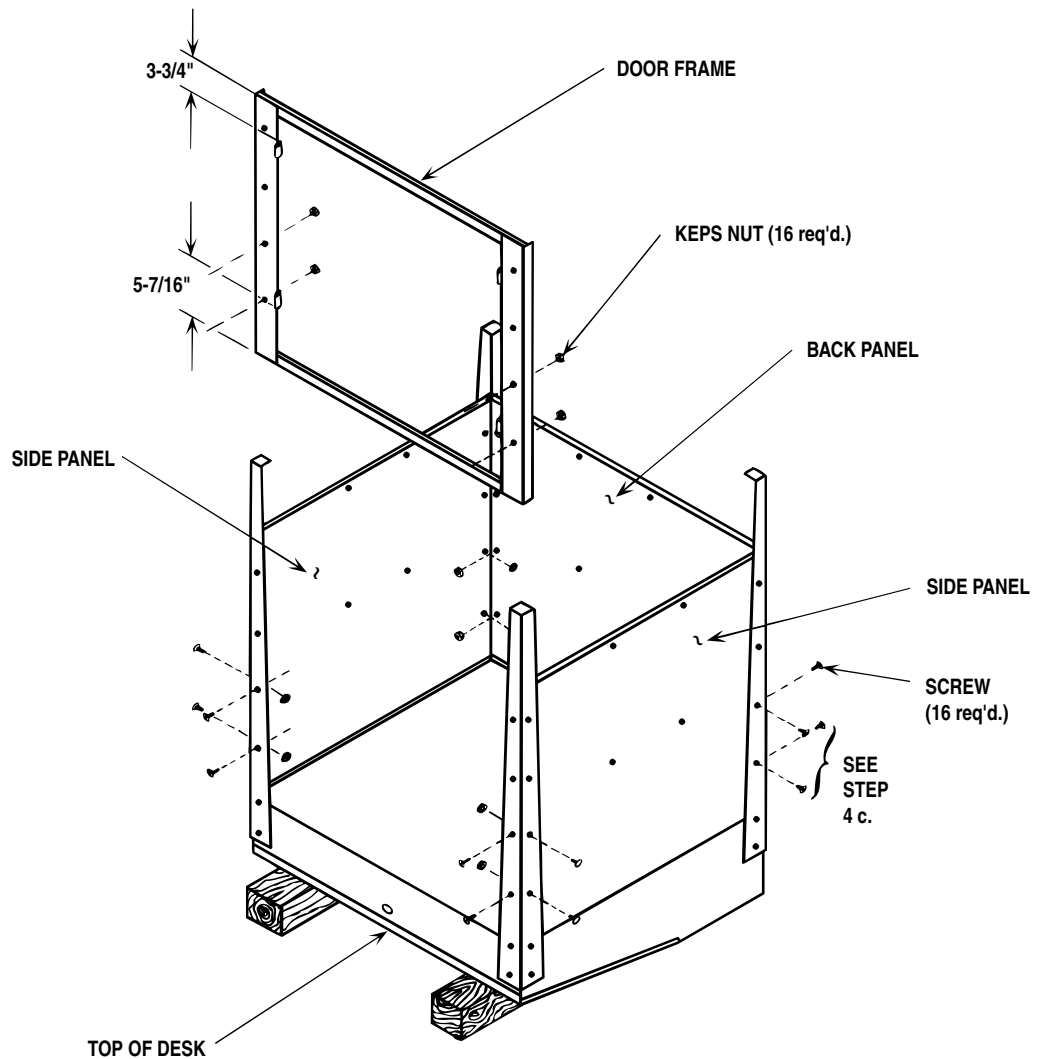

FIGURE 8

5. See Figure 9 and . . .

- a. Insert upper shelf (Item 13) and fasten into place with six (6) screws and nuts (Items 5 & 6).
- b. Fasten side and back panels to REAR LEGS ONLY with eight (8) screws and nuts (Items 5 & 6).
- c. Insert bottom shelf and fasten into place with six (6) screws and nuts (Items 5 & 6). **NOTE:** Tilt shelf between side panels and pull upward to align shelf with holes in side and back panels.
- d. Fasten door frame and side panels to front legs with eight (8) screws and nuts (Items 5 & 6).
- e. Place shop desk into upright position.

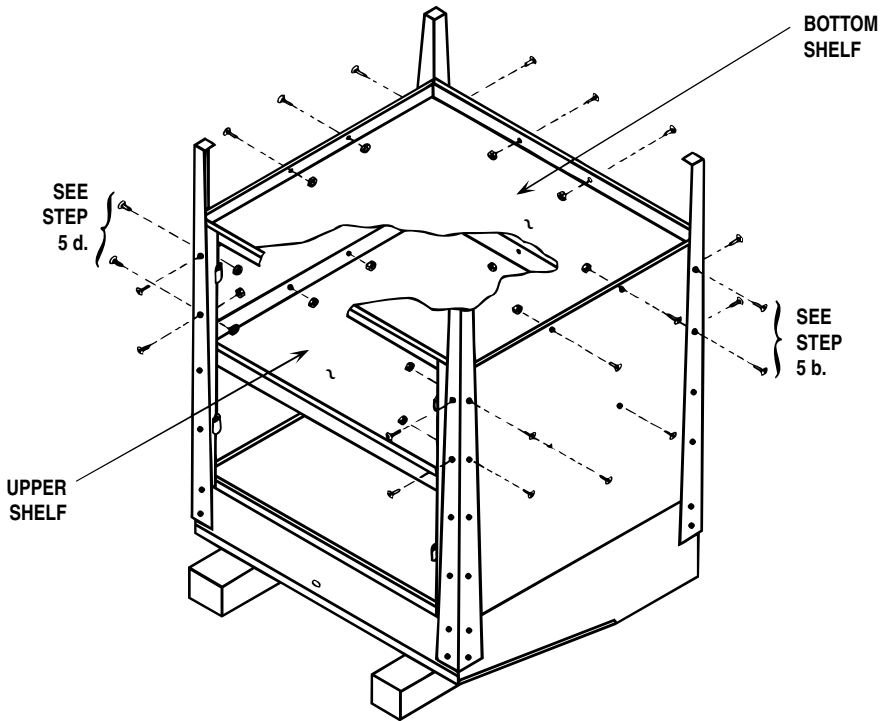

FIGURE 9

6. See Figure 10 and . . .

- a. Fasten handle reinforcement (Item 1) and door handle with lock (Item 2) to right hand door with two (2) screws (Item 4).
- b. Place throwbolts (Item 10) on pins of cam (Item 3) and fasten to handle with push clip (Item 15).

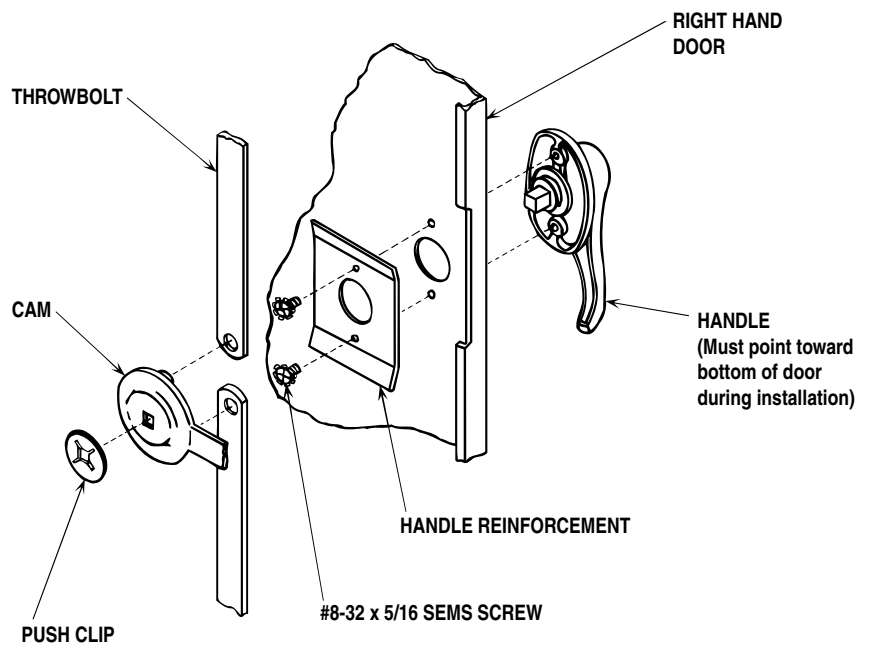

FIGURE 10

7. Attach left hand and right hand doors (Items 8 & 9) to door frame by inserting hinge pins into hinge sockets.
8. Fasten rack into original position on desk with four (4) screws.

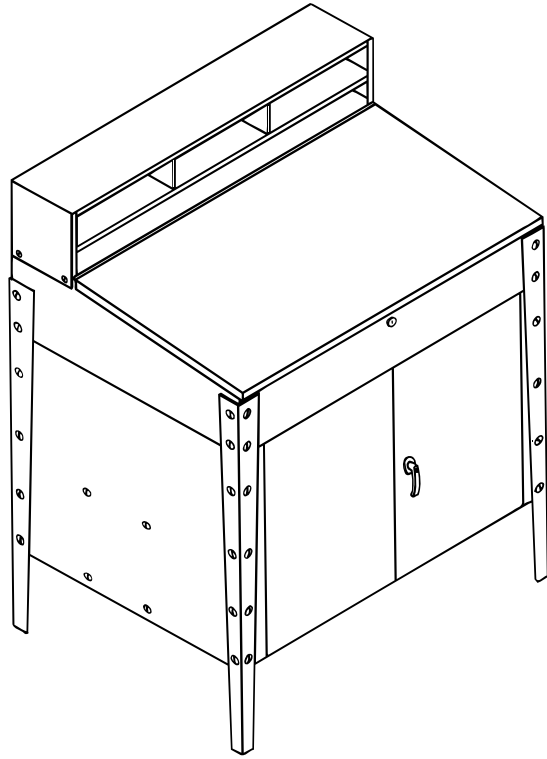

FIGURE 11

NOTICE:

Borroughs Corporation extends to the original purchaser from the date of purchase, a 5-year limited warranty against manufacturing defects in material and workmanship. If a Borroughs product fails to perform because of a manufacturing defect, Borroughs will examine it. If found defective, it will be repaired or replaced at our option. This warranty applies only to Borroughs products acquired directly from Borroughs Corporation or from Authorized Borroughs Dealers. This warranty does not apply to any product which has been subject to misuse, negligence, or accident; has been damaged in shipment, storage, or installation; has been misapplied or has been modified or repaired by unauthorized persons or been repaired with non-standard Borroughs replacements parts. This warranty specifically excludes claims for indirect, incidental, or consequential damages arising in any way from a product defect. This warranty is exclusive, and exists in lieu of all other warranties, either express or implied. This warranty gives you specific legal rights; you may also have other rights which may vary from state to state. To obtain warranty service, contact your Borroughs Selling Dealer. You must make a written claim. Provide a copy of your purchase record and a written description of the warranty problem with your claim. If you are unable to contact your Dealer, contact: Borroughs Corporation, Customer Service Manager, 3002 N. Burdick Street, Kalamazoo, MI 49004-3483.